

RATIONALE

UPDATE TO ASME Y14.5-2018. REVISE LEAD THREAD CHAMFER TO AS1132. REVISE LIGHTENING HOLE CONFIGURATION TO AS1132. REVISE FILLET RADIUS TO CR. ADD "COMPOSITION SIMILAR TO" TO NOTE 2.

REV.  
E

AS3240™

SAE Executive Standards Committee Rules provide that: "This report is published by SAE to advance the state of technical and engineering sciences. The use of this report is entirely voluntary, and its applicability and suitability for any particular use, including any patent infringement arising therefrom, is the sole responsibility of the user." SAE reviews each technical report at least every five years at which time it may be revised, reaffirmed, stabilized, or cancelled. SAE invites your written comments and suggestions.

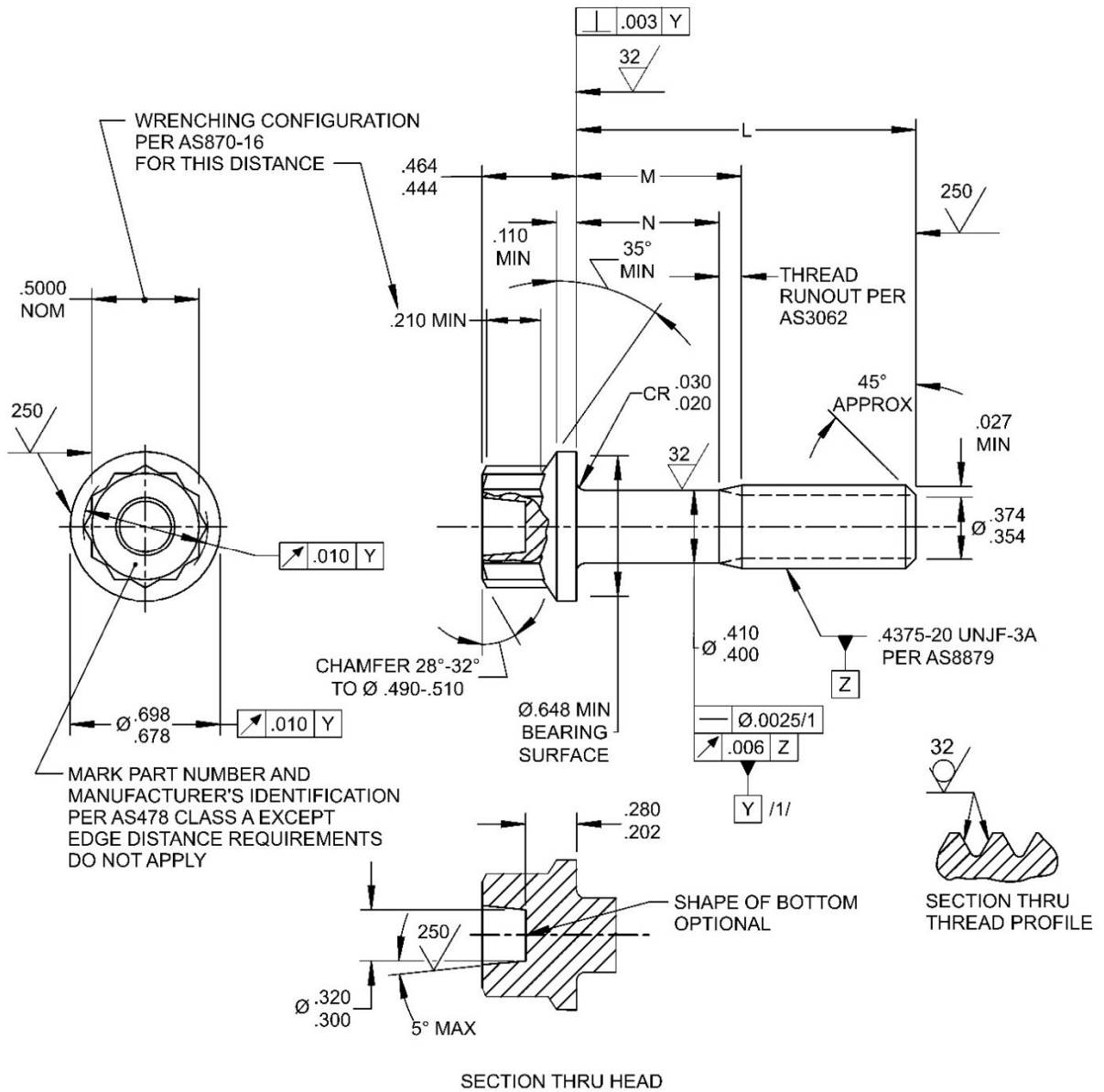
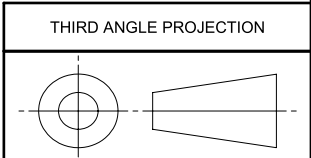

FIGURE 1 - BOLT

For more information on this standard, visit  
<https://www.sae.org/standards/content/AS3240E/>



CUSTODIAN: E-25

PROCUREMENT SPECIFICATION: AS7466



**AEROSPACE STANDARD**

BOLT, MACHINE - DOUBLE HEXAGON EXTENDED  
WASHER HEAD, PD SHANK, NICKEL ALLOY,  
UNS N07718, 185 KSI MIN, .4375-20 UNJF-3A

AS3240™  
SHEET 1 OF 3

REV.  
E

ISSUED 1980-07 REAFFIRMED 2007-06 REVISED 2022-08